

Tutorial on Dividing Wall Columns

Dennis O'Brien, Jacobs Consultancy

Normal or Direct Distillation

Of a three component system

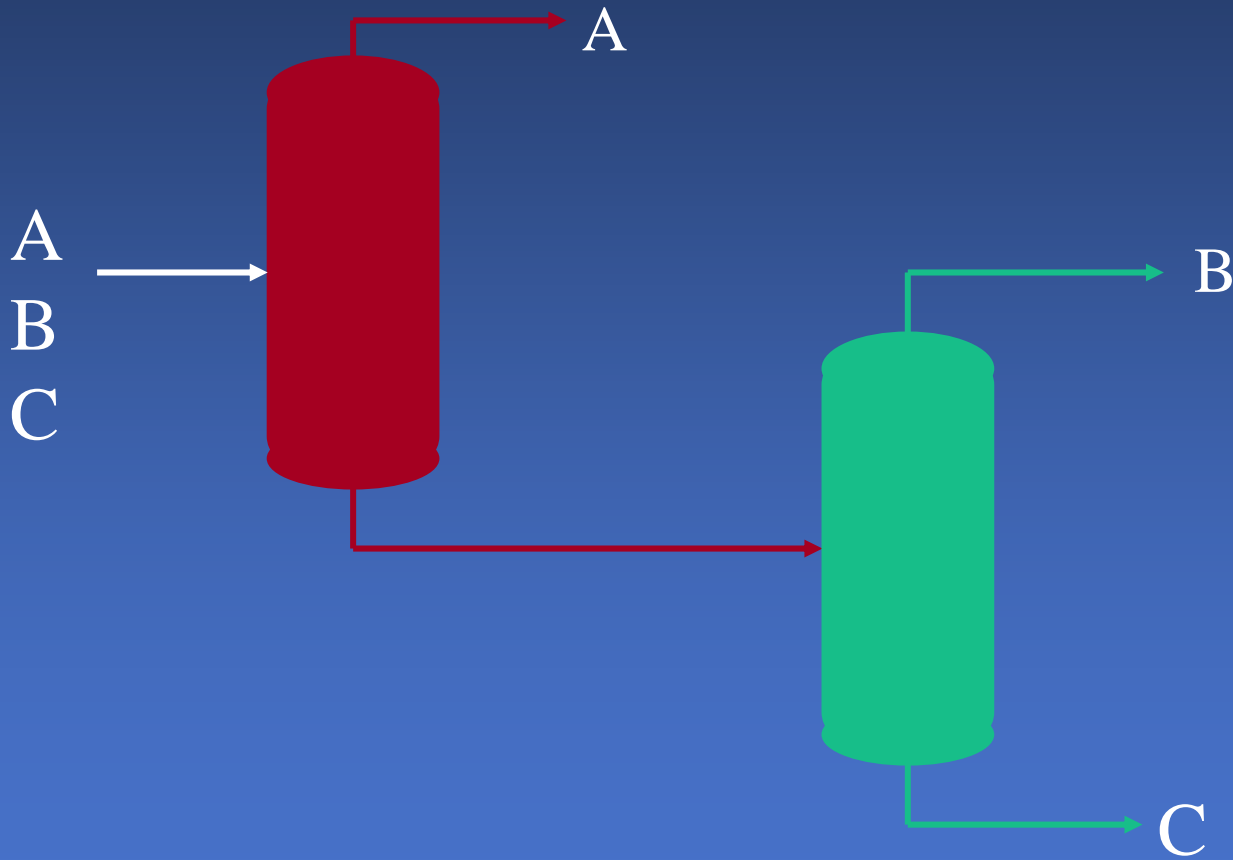

Thermodynamic Inefficiency Due to Remixing of Component B

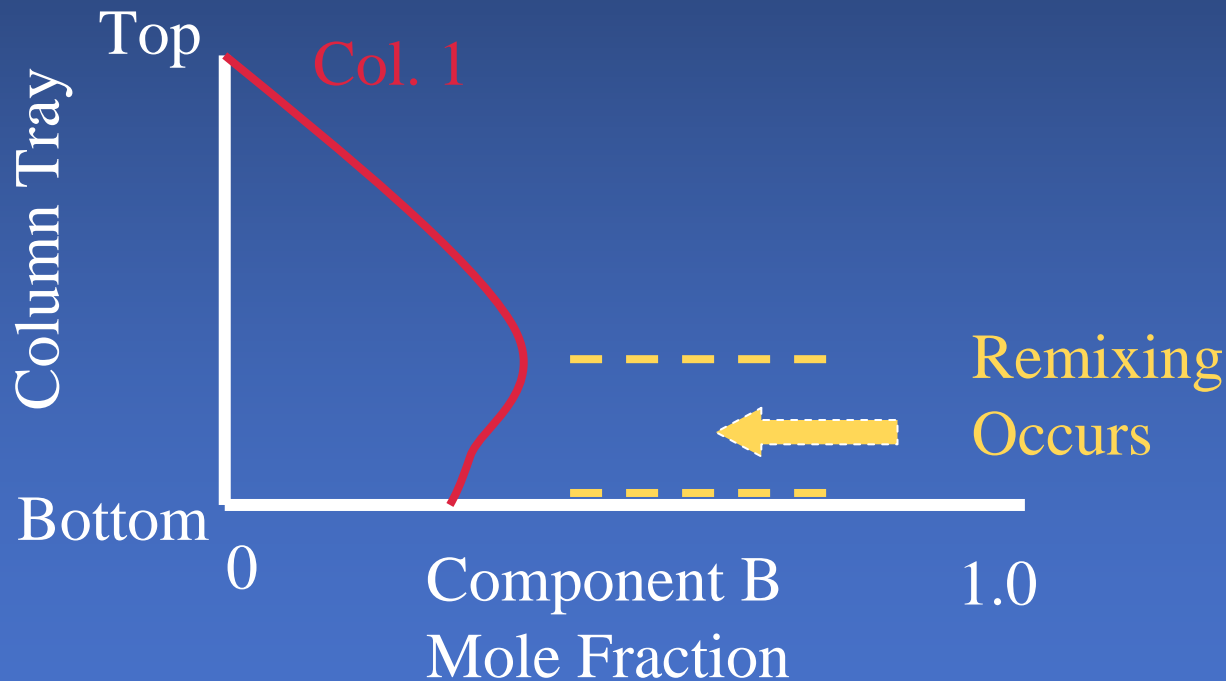

Component B Concentration in Rerun Col

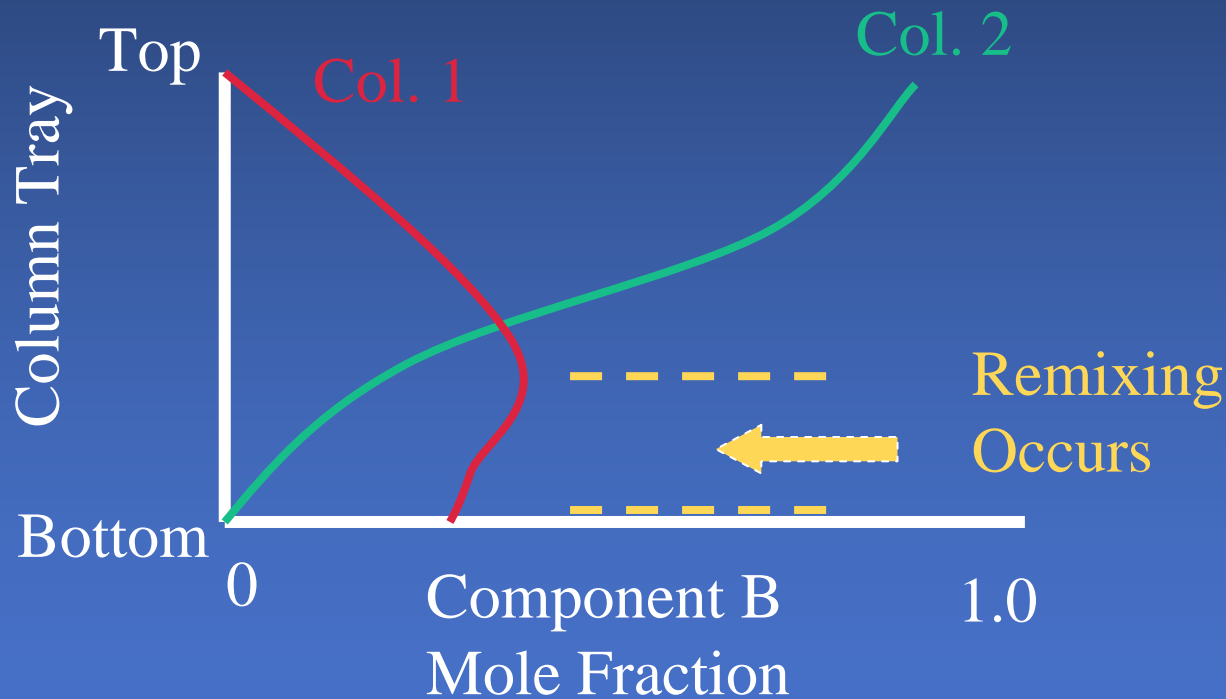

How Do We Eliminate this Inefficiency?

- **Avoid the concentration peak of B**
- **Lift some B into A**
- **Feed these product streams to 2nd column**
- **Effect of Prefractionator is to separate A from C**
- **Main Column separates B from A and C**

PreFractionator/Main Column Arrangement

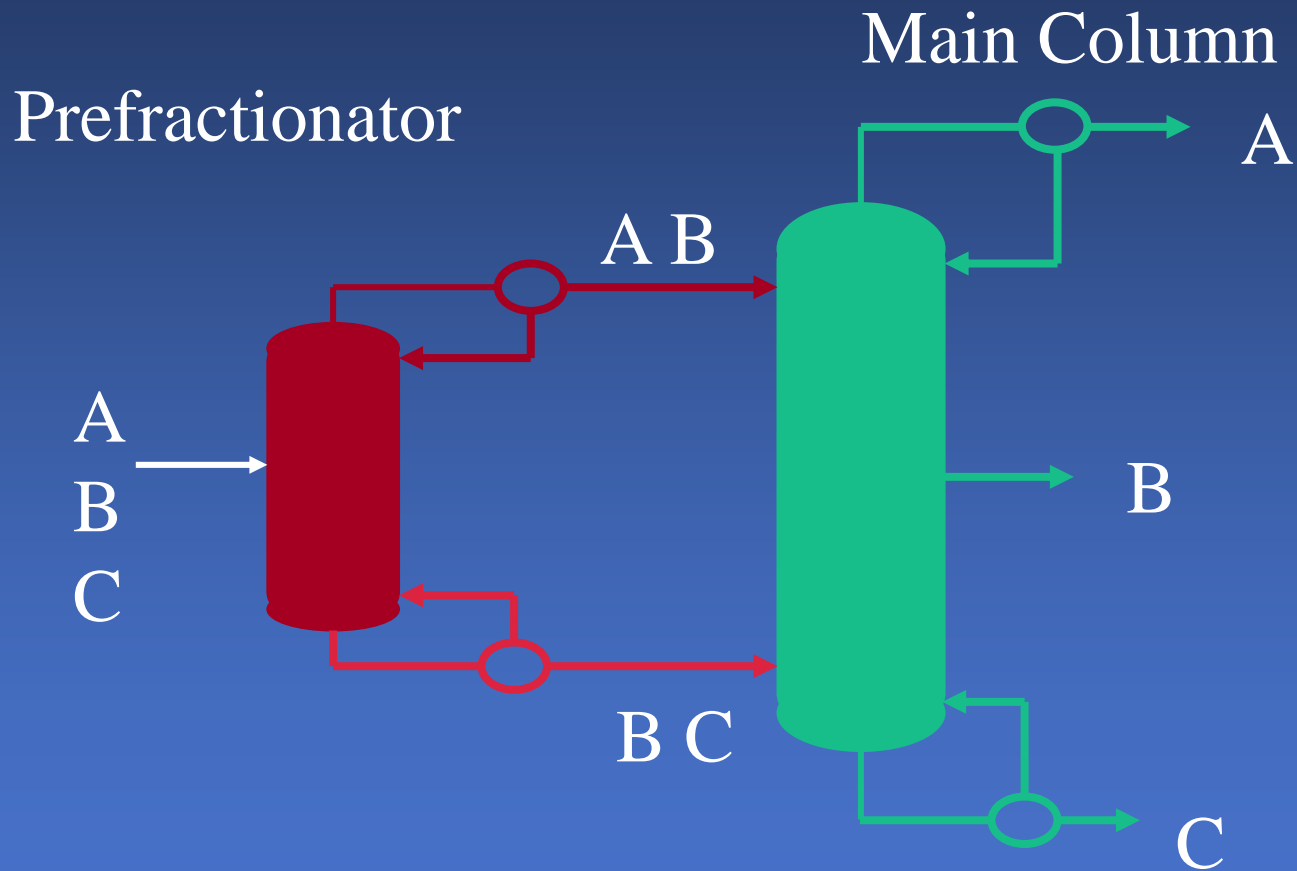

What happens in Main Column?

- **A must be separated from B**
- **B must be separated from C**
- **Two heat integrated sections**
- **Energy used to separate B from C is reused to separate A from B**

Profile of B in Prefractionator Column



Remixing of B is Now Eliminated

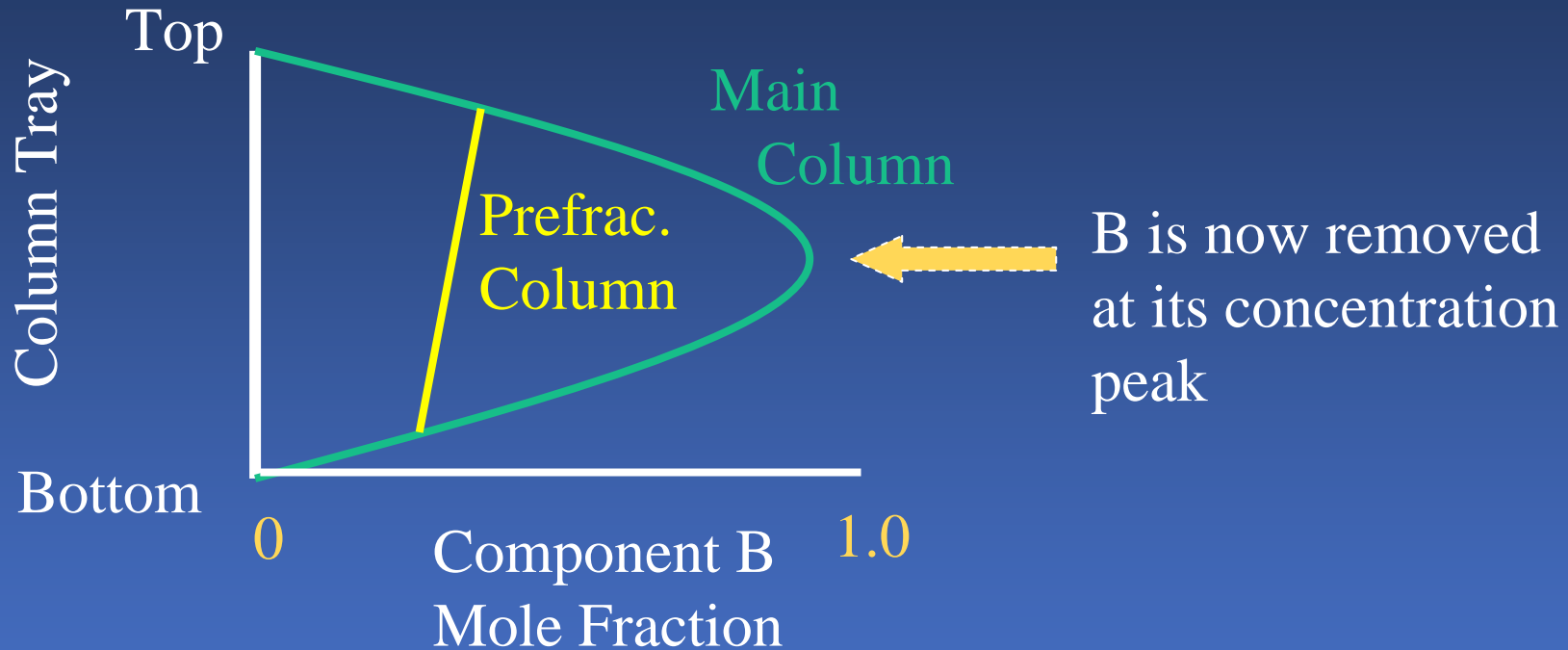

The Thermodynamic Inefficiency Has Been Eliminated

From Prefrac to Dividing Wall

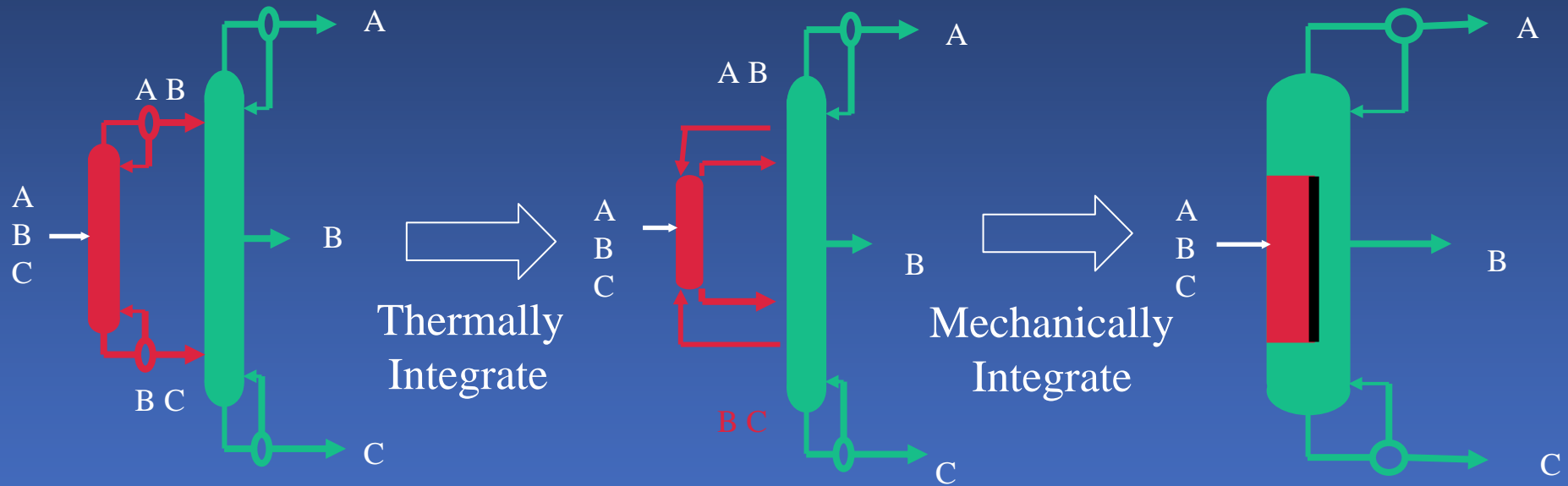

Prefractionator
Arrangement

Thermally Coupled
Prefractionator
(Petlyuk Column)

Dividing Wall
Column

Summary of Changes

- **Remixing inefficiency has been removed**
- **Heat of separation of B from C is reused in separating A from B**
- **Changes result in typical savings of 30% in energy**
- **Reduction in equipment count and cost give savings of ~30%**
- **ITS RARE TO HAVE BOTH CAPITAL COST AND UTILITY REDUCTION !**

Acknowledgements

- **Dr. Mike Schultz, UOP**
- **Dr. Gavin Towler, UOP**
- **Jim Harris, UOP**
- **Doug Stewart, UOP**
- **Steve Rosenblum, UOP**
- **Kirk Detrick, UOP**