Refining Heavy Oil

Presented by: Rich Hill (Jacobs Consultancy)

Presented for: AICHE Chicago

Date: October 10, 2006

City: Chicago, IL

Heavy Oil Crude Refining Agenda

- Alberta Oil Sands Reserves and Production
- Bitumen Derived Feedstock Qualities
- Historical Pricing
- Refining Considerations
- Capital Options
- Jacobs Capabilities

Setting the stage for Alberta Oil Sands

- Global factors
 - Oil demand increasing, growth markets
 - Energy pricing
 - Security of supply
- Positive factors for Alberta oil sands
 - Size of the reserves
 - Technology developments
 - Production and upgrading
 - Market access
- Recent Announcements
 - Upgrading (CNRL, BA Energy, Encana, Suncor, Shell, Suncor)
 - Refining (Premcor, Flint Hills)

Oil Sands Contain Bitumen



- 12% oil in the “oil sands”
 - Needs to be extracted and separated from the sand
- Oil is referred to as bitumen
 - Heavy, sour, poor quality, difficult to deal with

Alberta Oil Sands Reserves

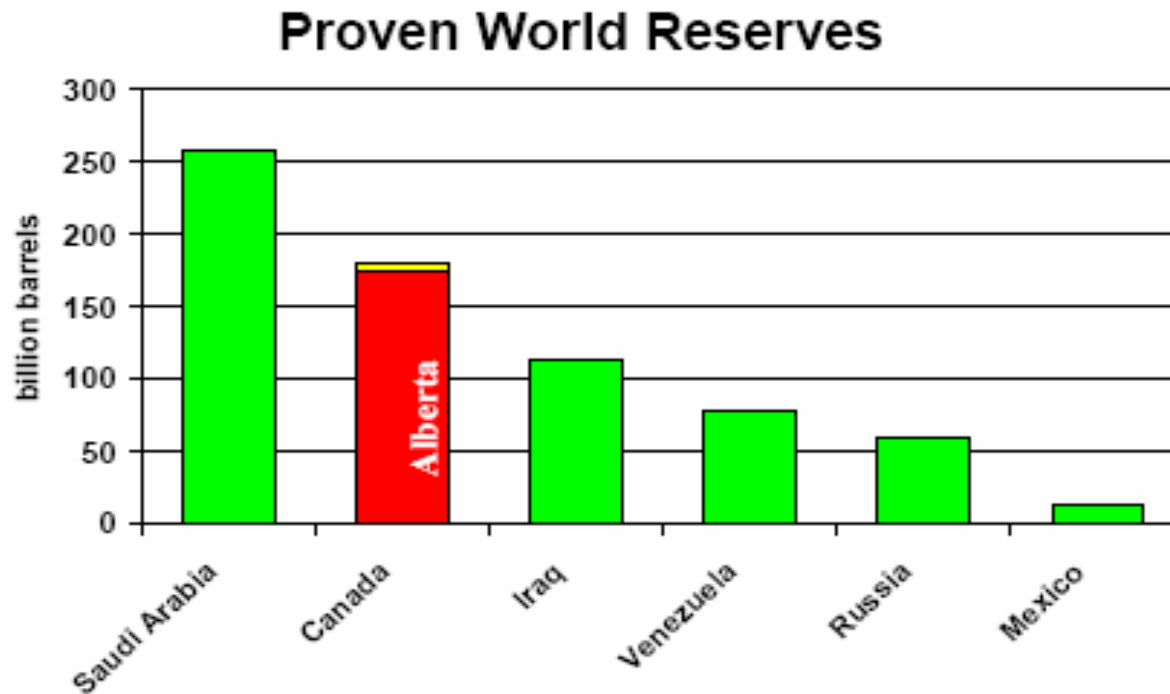

Source: Alberta Department of Energy

Alberta Production

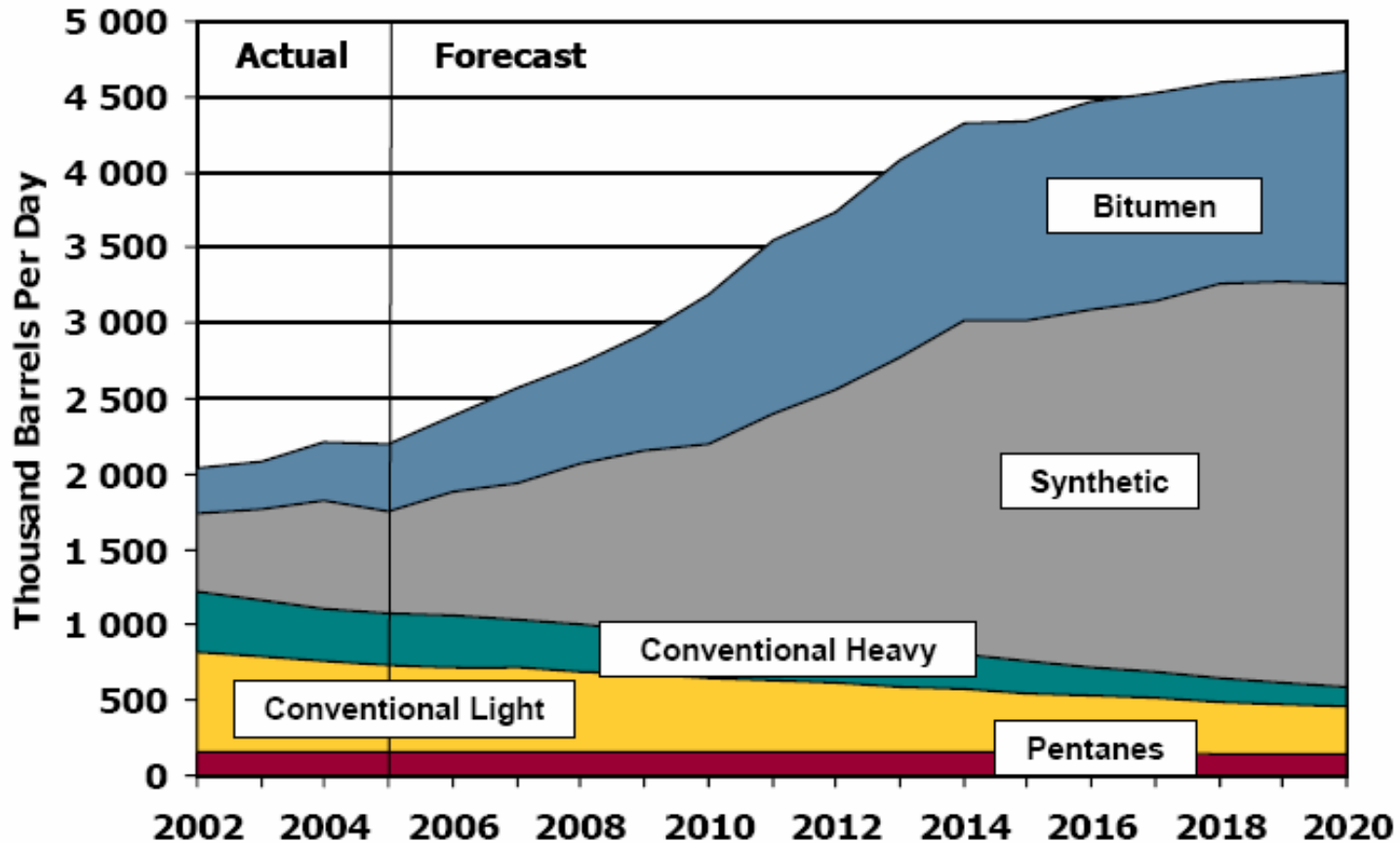

Source: CAPP – May 2006

Note: Production forecast increasing vs 2005

Existing Markets - Relative Volumes

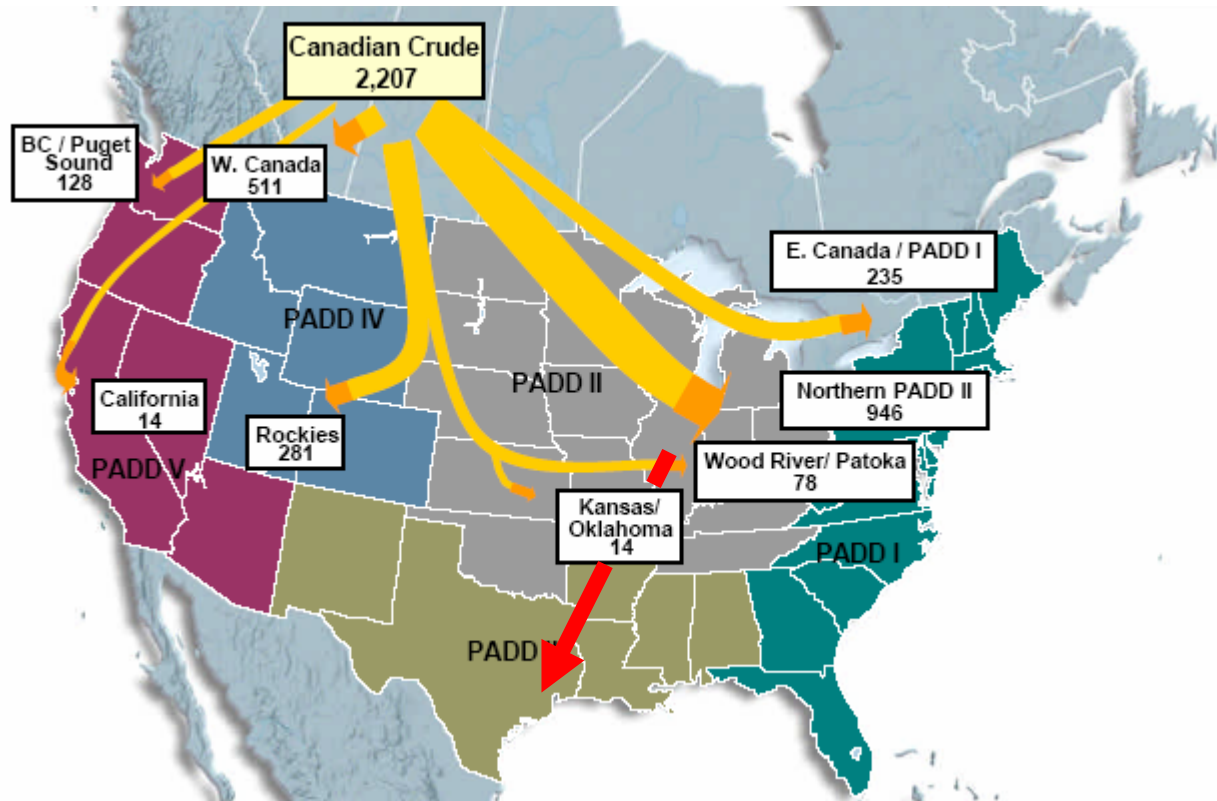

Source: CAPP 2005 volumes

Note: USGC access established 2006 – 80 kbpd

Bitumen Upgrading / Technologies

General bitumen qualities

	Athabasca Bitumen	Arab Heavy
API	8.0	27.4
Gravity	1.015	0.891
Sulfur, wt%	4.9	2.8
Nitrogen, wt%	4000	1600
CCR, wt%	13.6	6.8
Nickel, ppm	92	16
Vanadium, ppm	226	55
Asphaltenes, wt%	18.1	6.2



Making Motor Fuels

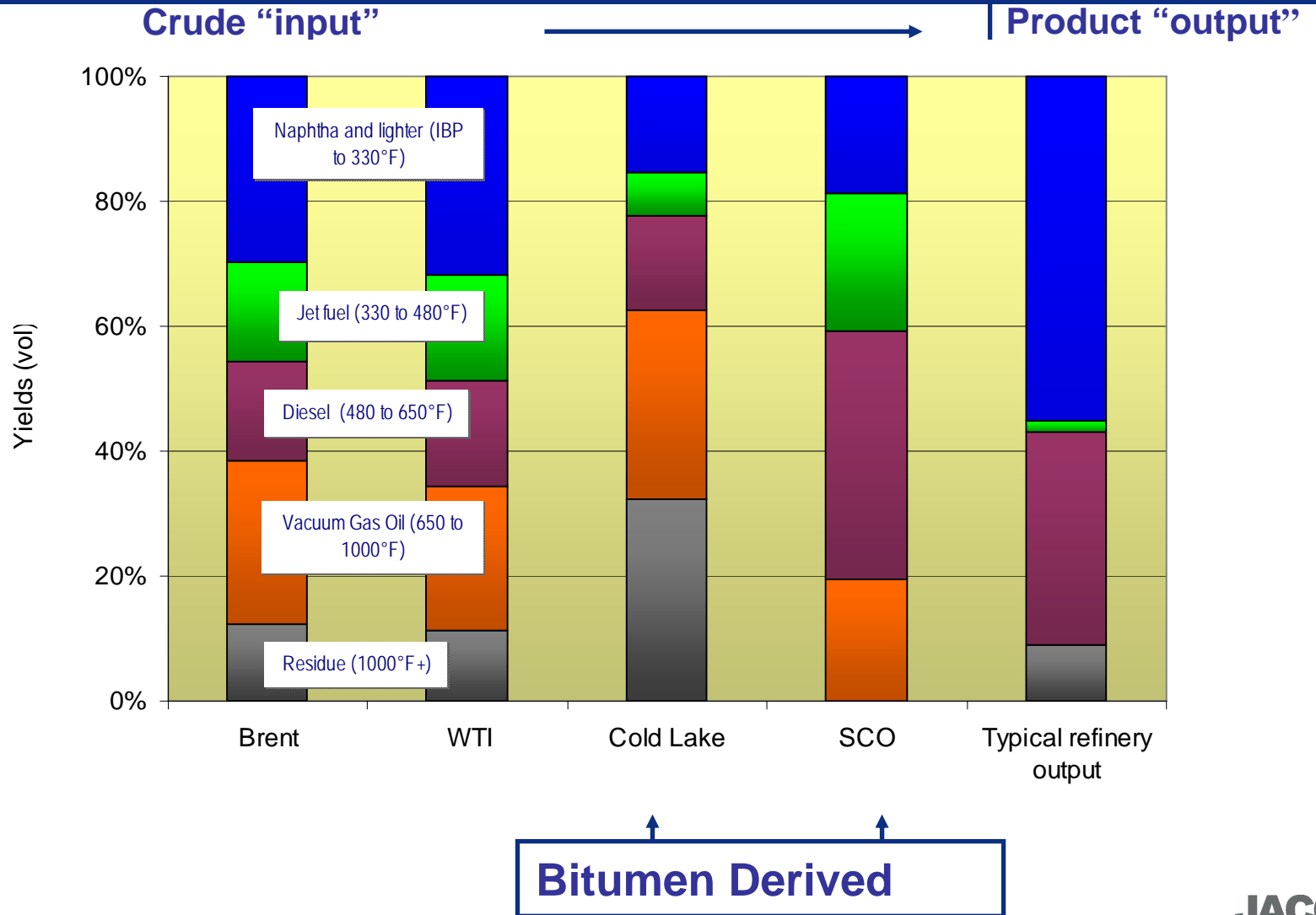

Refining Considerations for Dilbit and SynBit

- Poor quality in all boiling ranges
 - Significant resid fraction with poor quality
 - Primary upgrading choices have big impact on cost, complexity, products, etc.
 - High sulfur, nitrogen, CCR and metals
 - Requires severe treatment (and hydrogen addition)
 - Catalyst issues and other constraints result
 - High TAN
 - Requires upgraded metallurgy and design care
 - Highly aromatic throughout all boiling ranges (includes SCO)
 - Impacts processing choices and product qualities



Relative Value of Bitumen derived Feedstocks

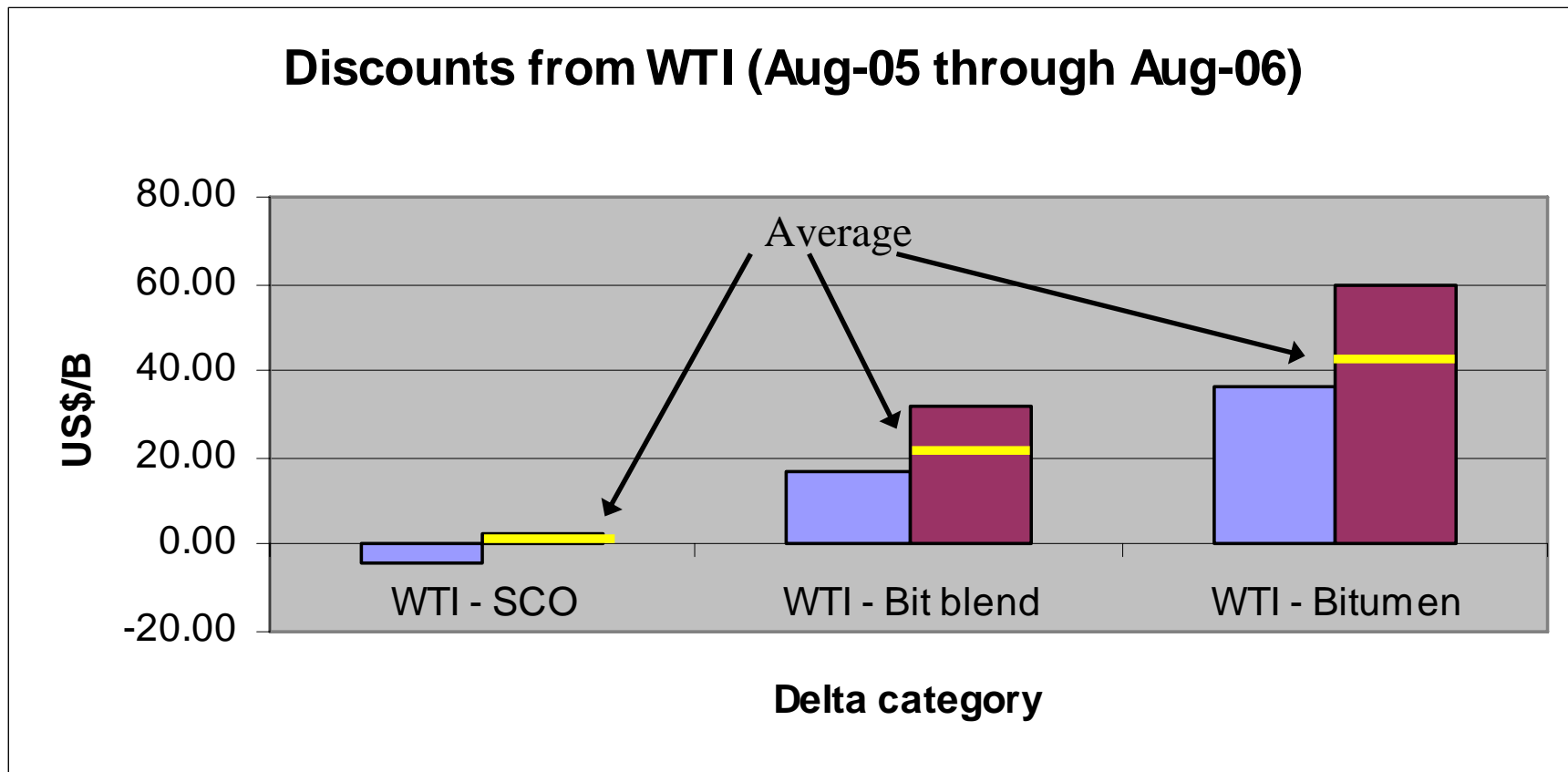

Refining Issues

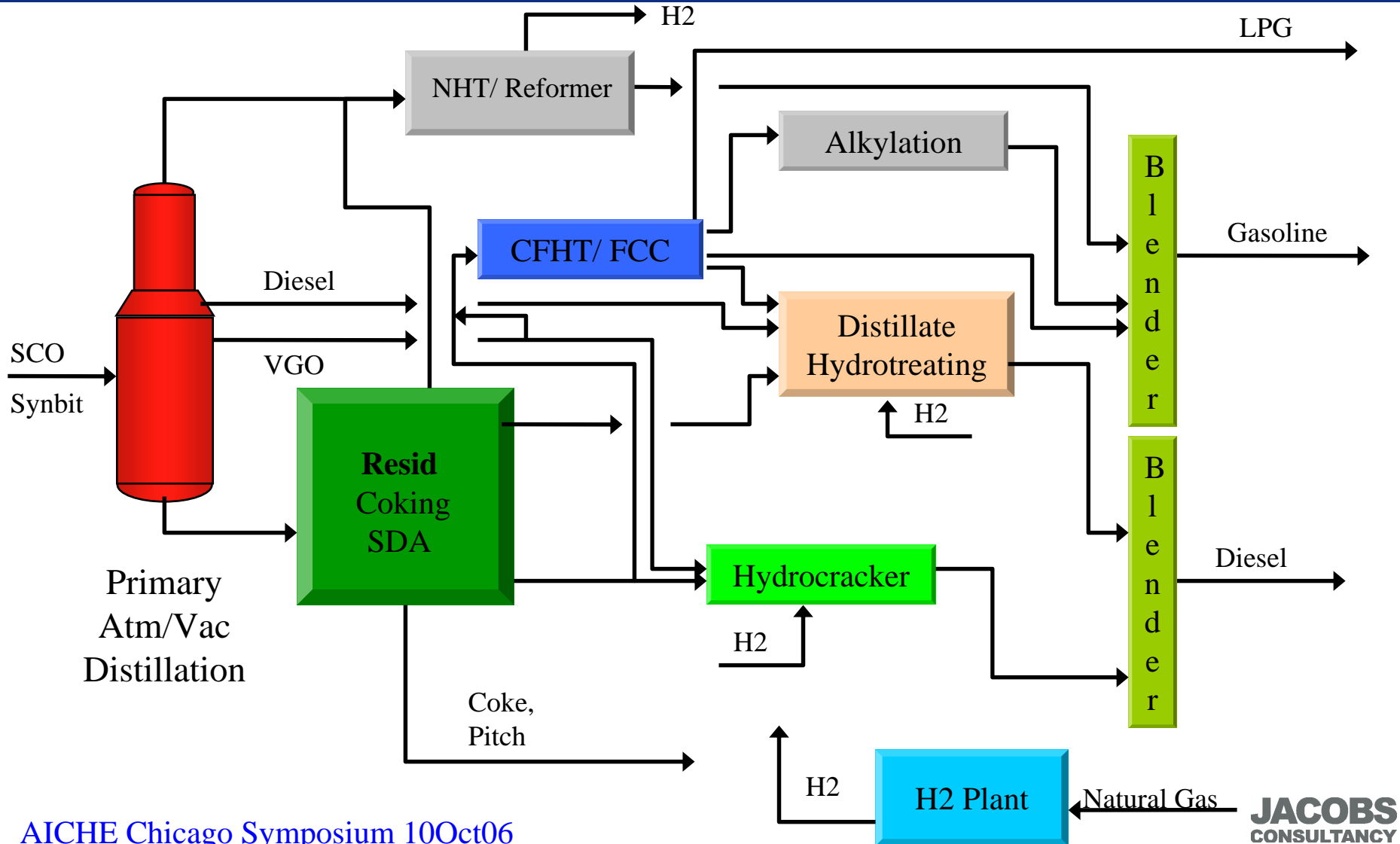

Refining - CDU/VDU

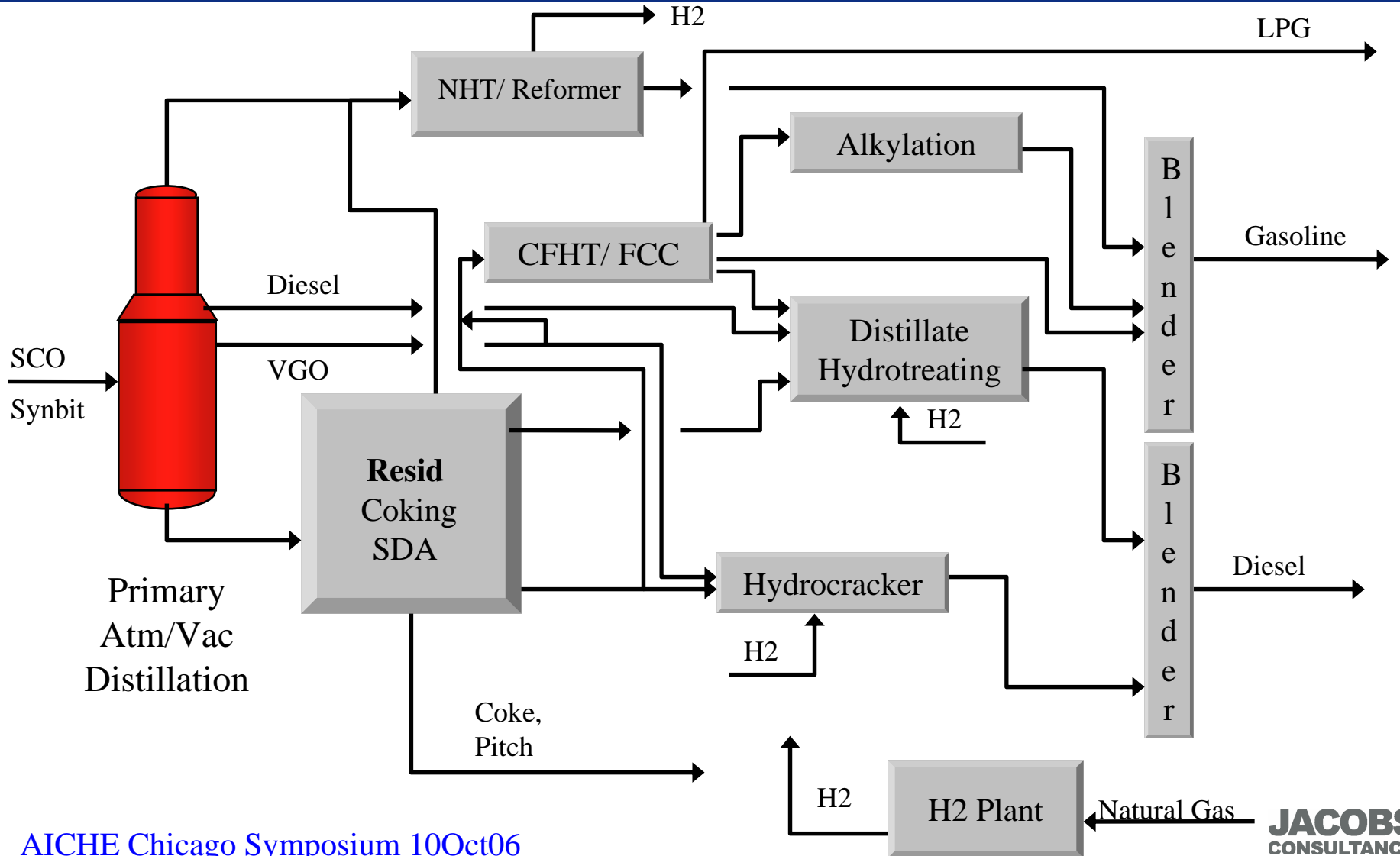

Refining - Bottoms Conversion

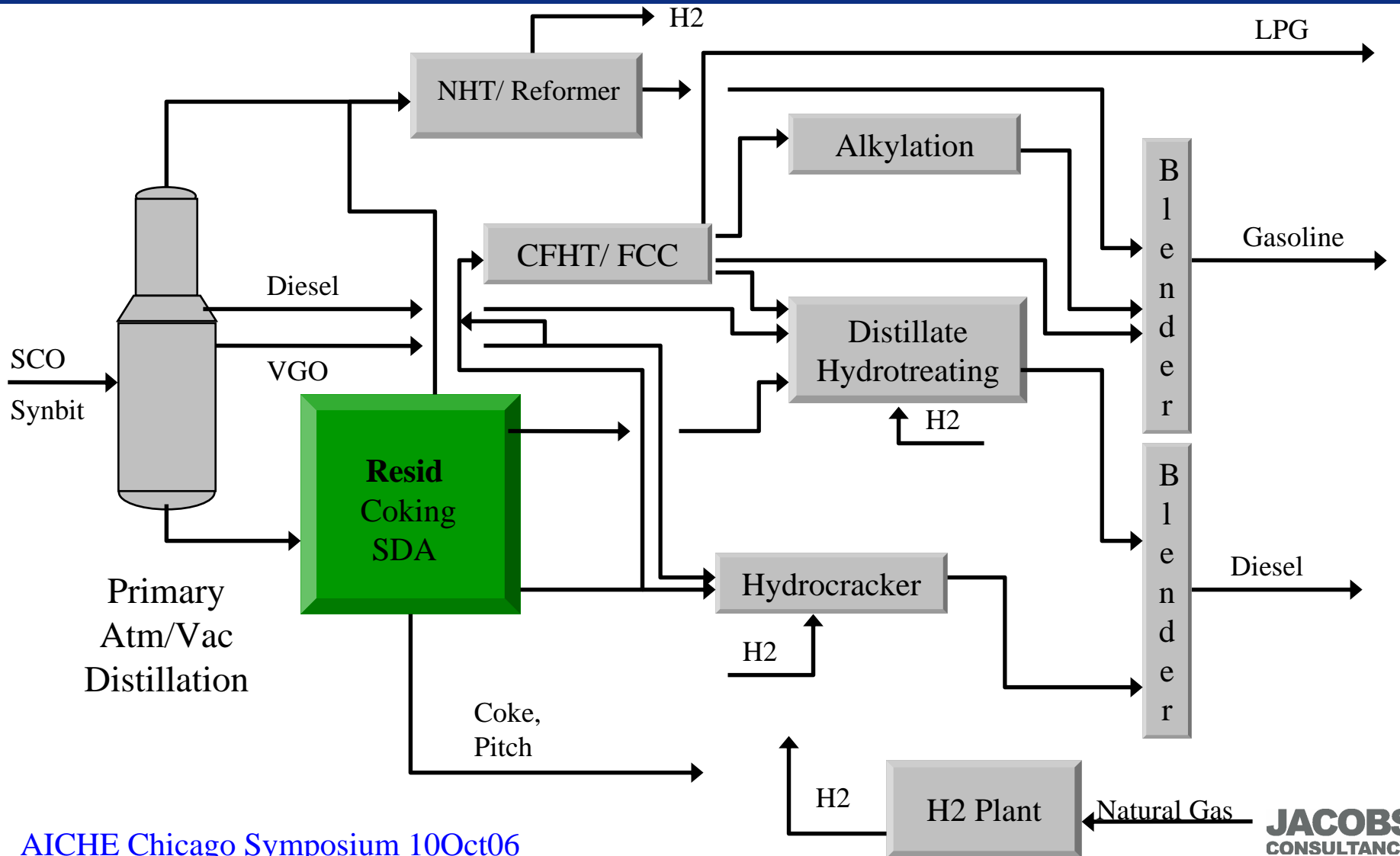

Refining - Secondary Conversion

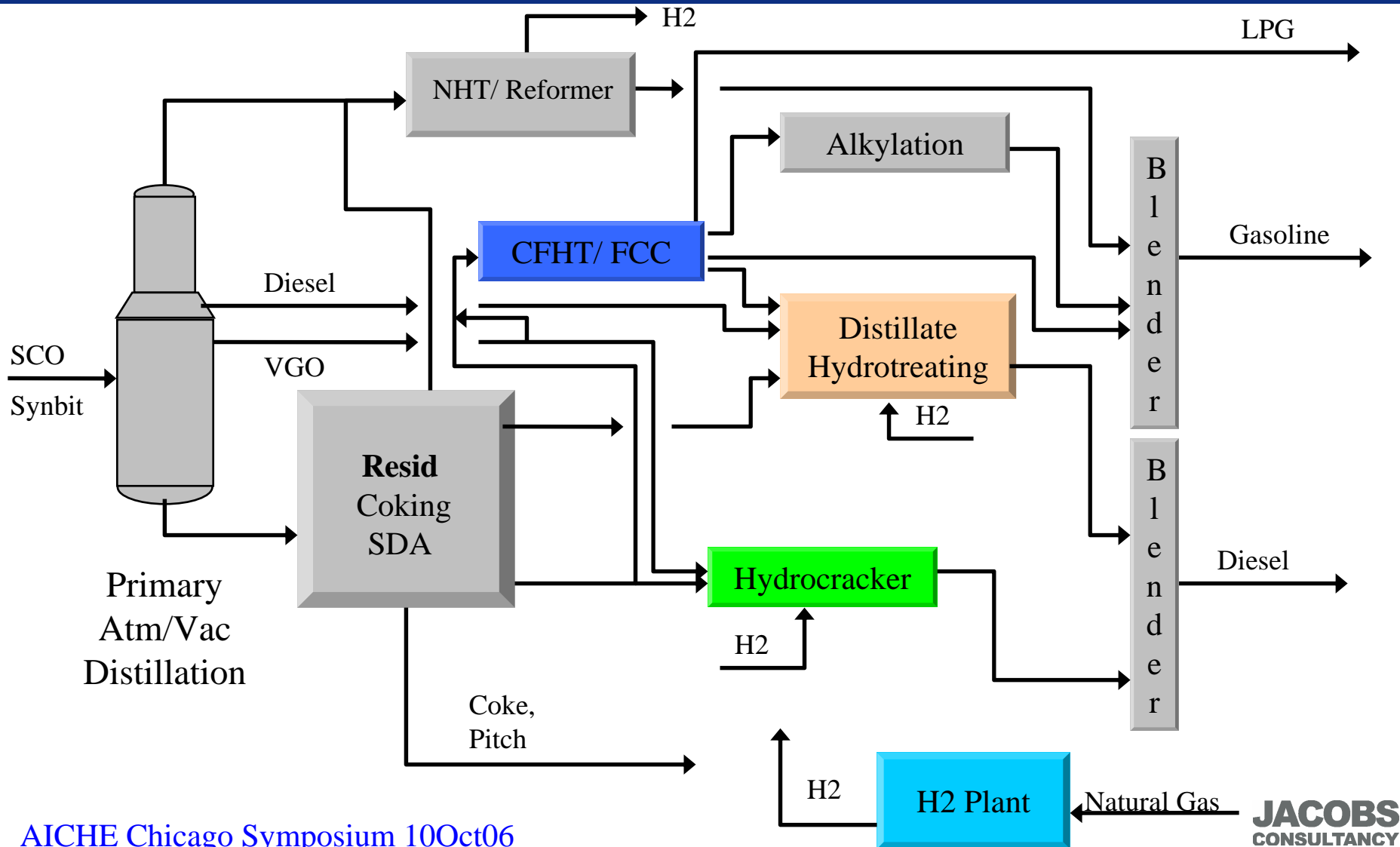

Refining - Blending

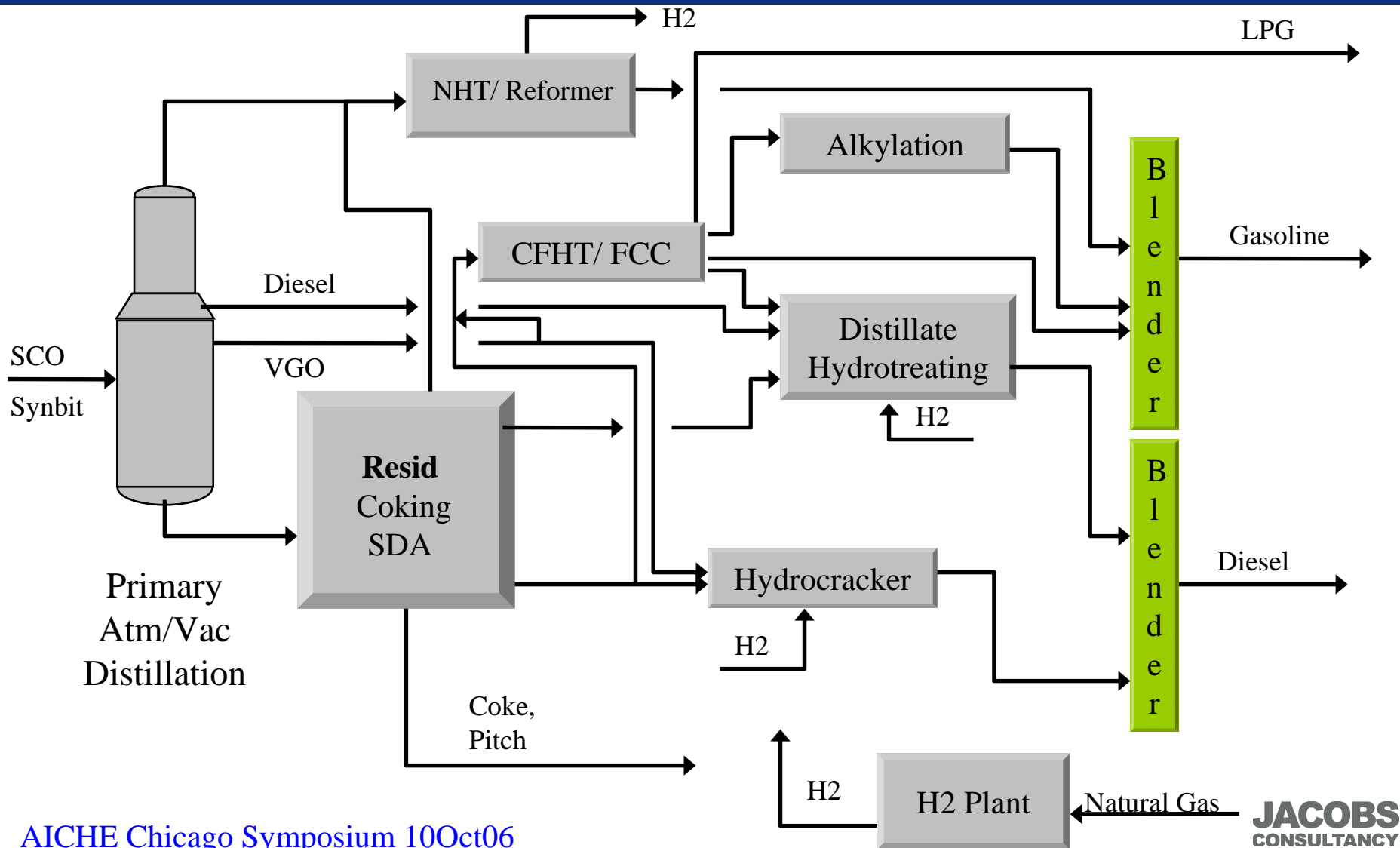

Recent Projects

- Economics, risk tolerance and pre-existing assets drive strategies
- Lower quality feedstock (Dilbit/Synbit)
 - higher margin
 - higher investment
- Recent projects span the range of options

Investment Options

- High Investment (Client A – Midwest US Refinery)
 - Large volume of bitumen feedstock
 - New units or major modifications:
 - CDU/VDU
 - Coker
 - Integrated Hydrotreater/ Hydrocracker
 - Other Unit revamps
 - Utilities and Offsites
- Low Investment (Client B – Eastern US Refinery)
 - “Advantaged” Crude feedstock
 - Minor Modifications
 - FCCU upgrades
 - CDU/VDU upgrades
 - SDA expansion

Post Investment Changes

- Blending
 - Cetane Index
 - Blendstock requirements
 - Tankage optimization
- LP improvements
 - Unit representations
 - Supply chain effects
 - Turnaround planning
- New Fuel regulations

Jacobs Expertise

Project Planning

- Market Evaluation
- Economic Evaluations
- Energy Analyses
- Permitting Studies
- Site Selection, Development and Planning
- Technology Comparisons
- Process Designs
- Licensing Studies
- Energy Strategies
- Capital Estimates
- Project Justification Analyses

Development and Implementation

- Project Management
- Process Safety Management
- Process Simulations
- Design Engineering
- Definitive Estimates
- Process Control Strategies
- Purchasing, Expediting and Inspection
- Cost Control and Analyses
- Planning and Scheduling

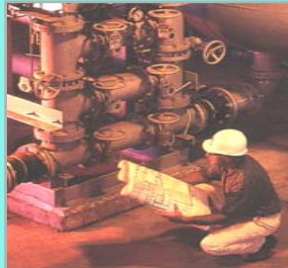

Start-up and Operation

- Construction
- Construction Management
- Precommissioning
- Mechanical Completion
- Offsite Construction (Modularization)
- Start-up
- Contract Maintenance
- Contract Plant Operation
- Maintenance Programs
- Turnarounds

Summary

- Bitumen derived feeds are here and now
- Capital Investment is underway at Refineries
- New designs require thought and planning
- Access to feedstock is an important consideration
- Large range of investment options
- Optimizing operations will be important in maximizing return on investment