

Utilizing Heat Transfer Technology to Provide Process Solutions

Mike Buettner
Koch Heat Transfer Co, LP



Presentation Topics

- Heat Transfer Technology
- Twisted Tube Fundamentals
- Crude Process Case Studies

Hairpin Heat Exchangers



Various Tube Inserts

- Twisted Tape
- Cored-Helix
- Heli-Core



Tank Heaters

HL Heater

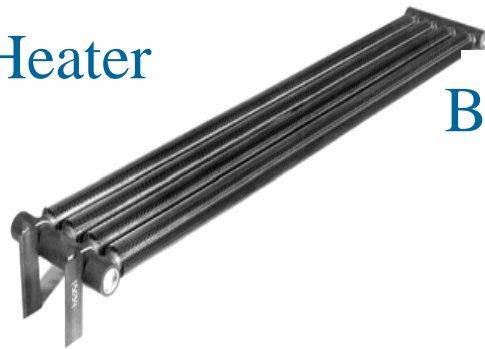

Bayonet Heater



Serpentine Heater



Line Heater

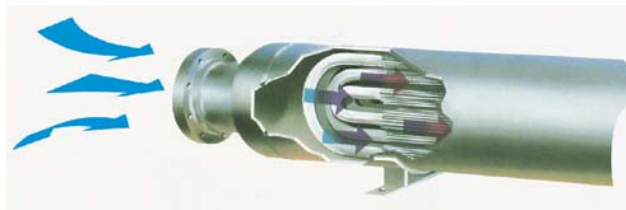

Vertical Heater



Man-way Heater

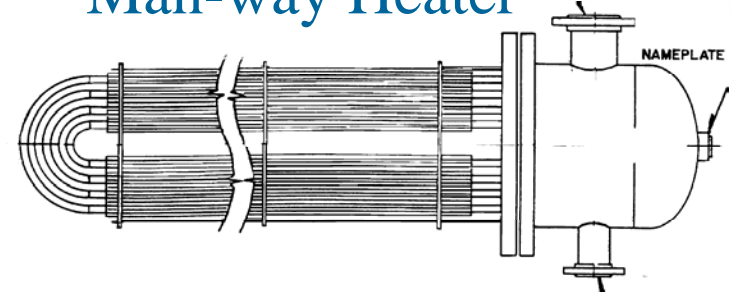

Suction Heater

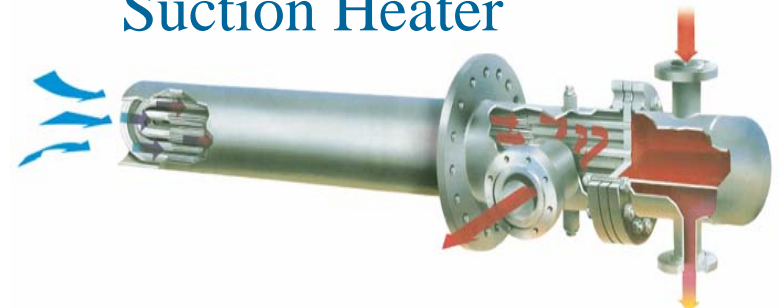

K KOCH
HEAT TRANSFER COMPANY LP

HELI-BAFFLE™



Twisted Tube[®] Technology



Twisted Tubes®



Twisted Tube[®] Technology

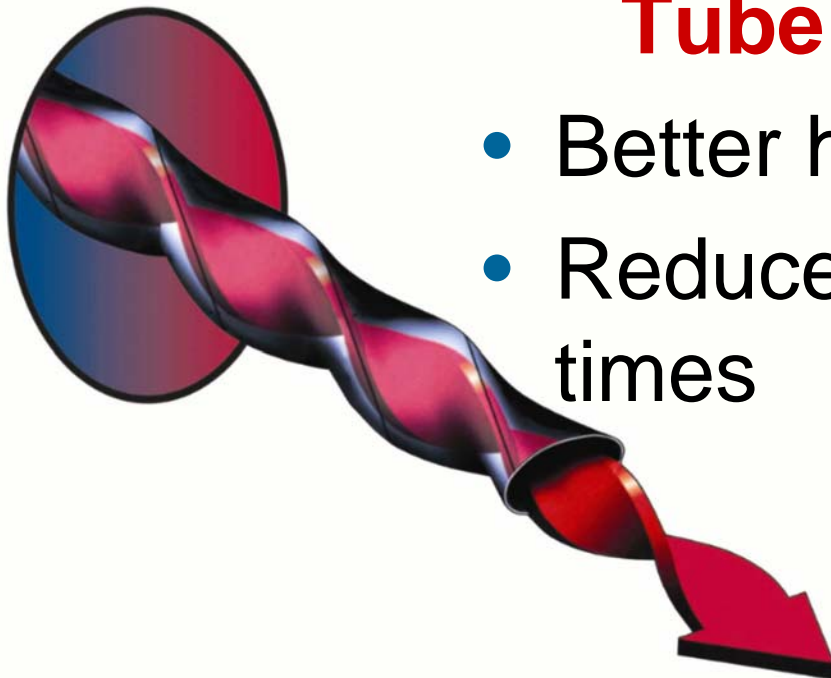

Tube Side Swirl Flow

- Better heat transfer
- Reduced fouling/Longer run times

Bundle Construction

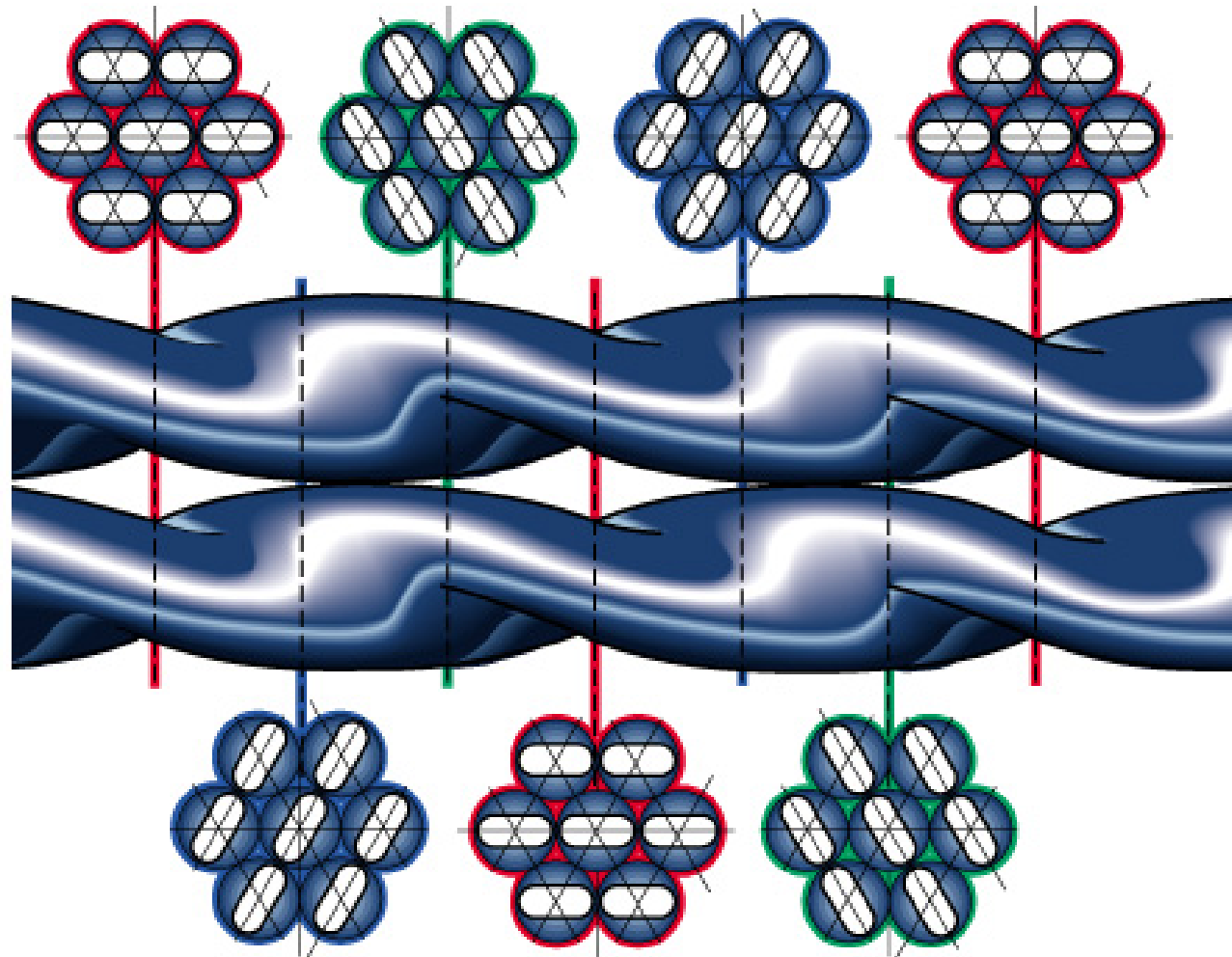

Shell Side Interrupted Swirl Flow

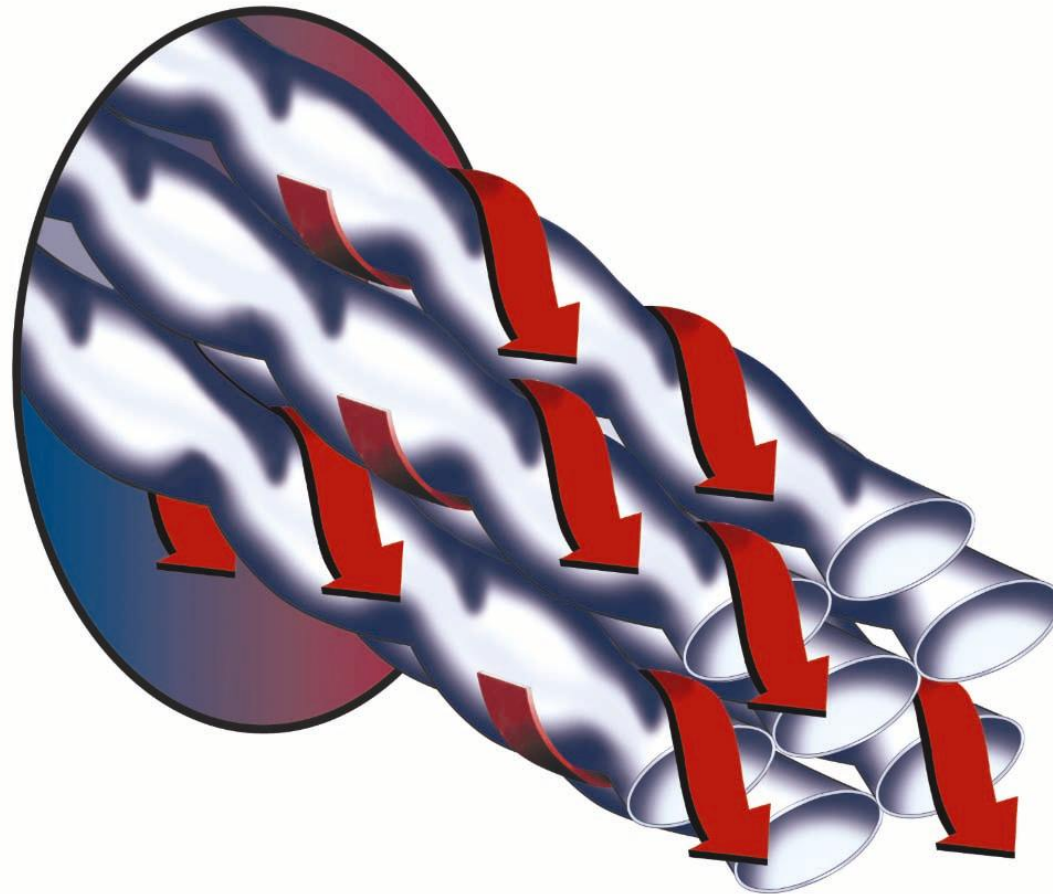

Baffle-free design means **lower**
pressure drop & **no** dead spots

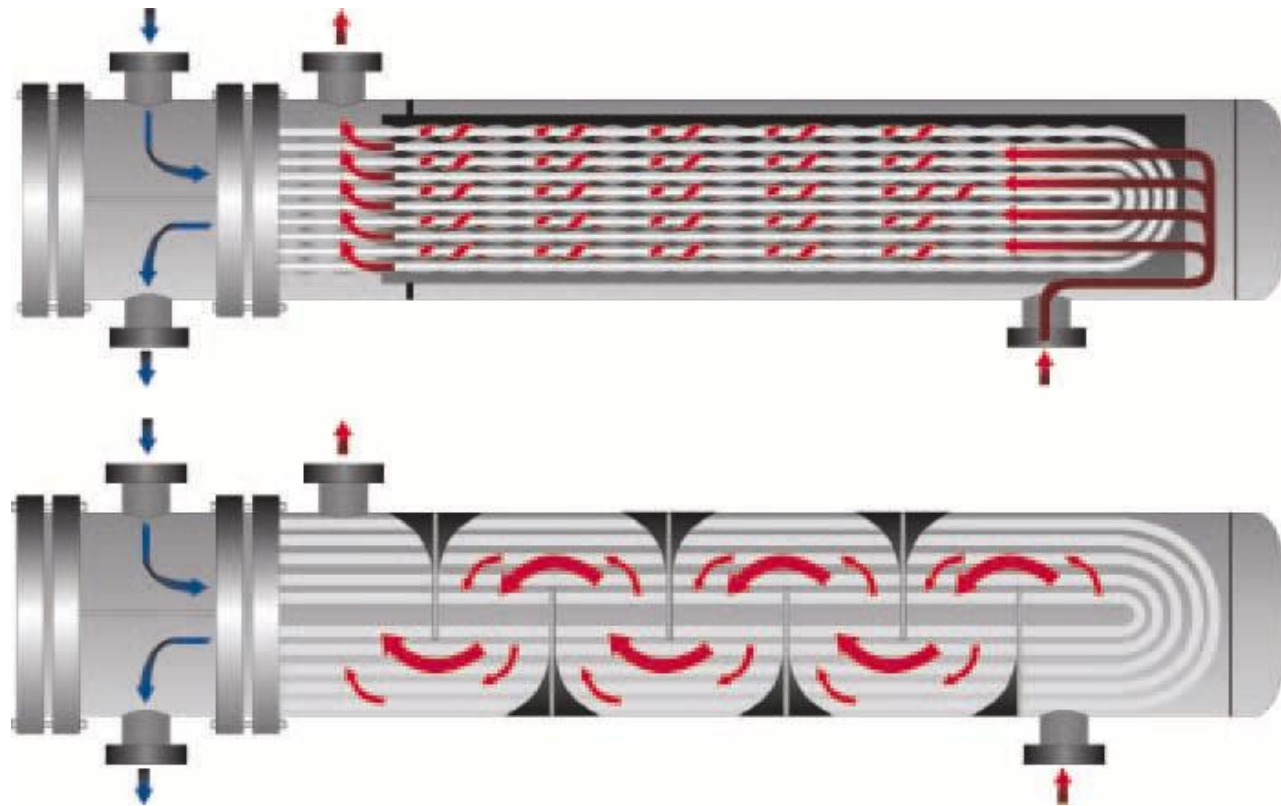

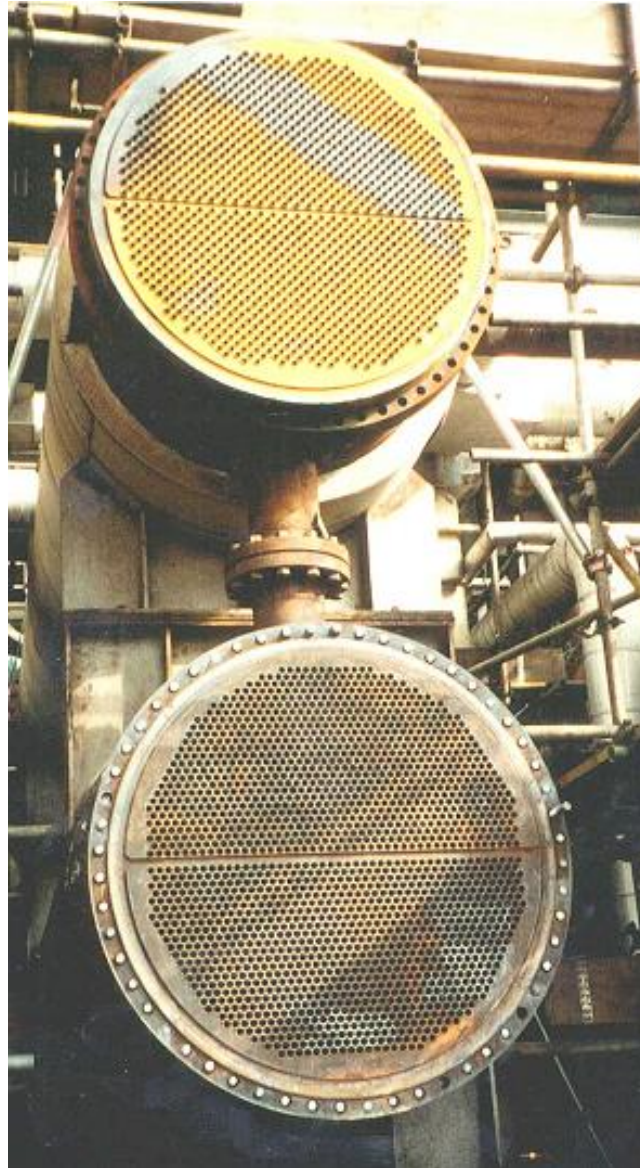

Increase in tube
count by **45%**

1" square pitch
vs
0.886" triangular
pitch



Twisted Tube® Shroud



- Directs fluid flow to prevent bypass
- Supports bundle within shell
- Impingement protection when needed



**TWISTED TUBE™
“F” BUNDLE IN “E” SHELL**

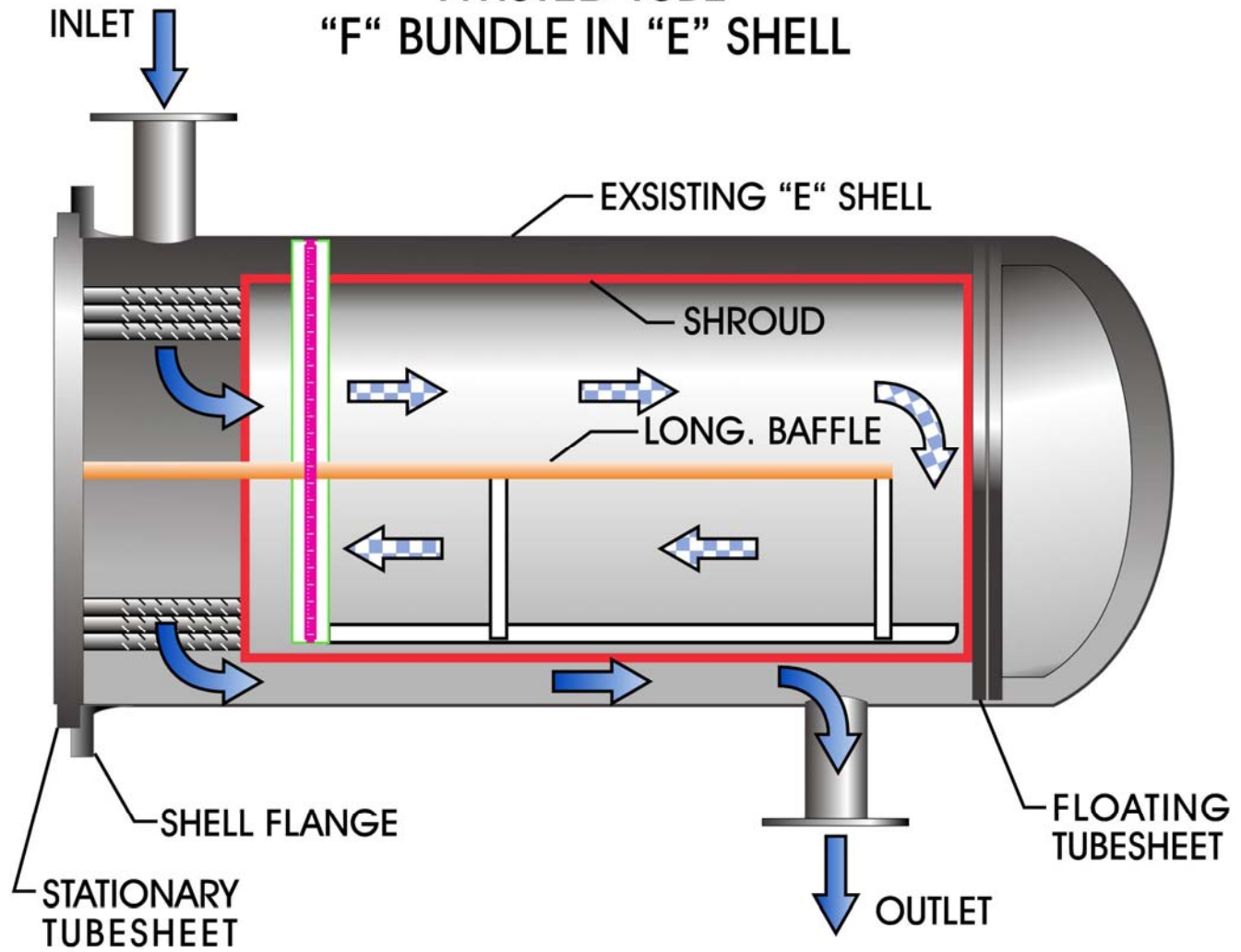

3 Pass bundle in a 1 Pass Shell



Shroud Design

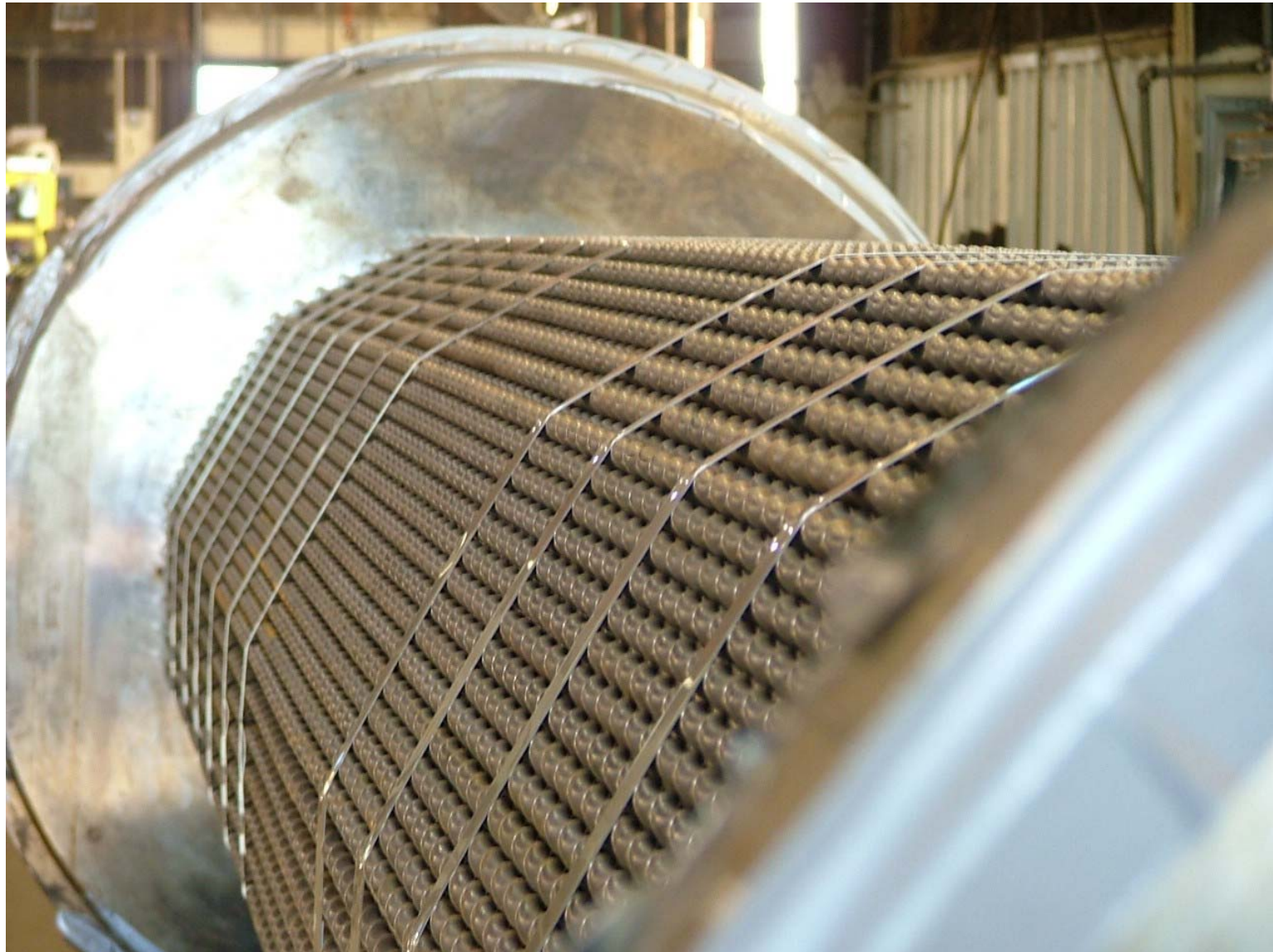

Shroud Design

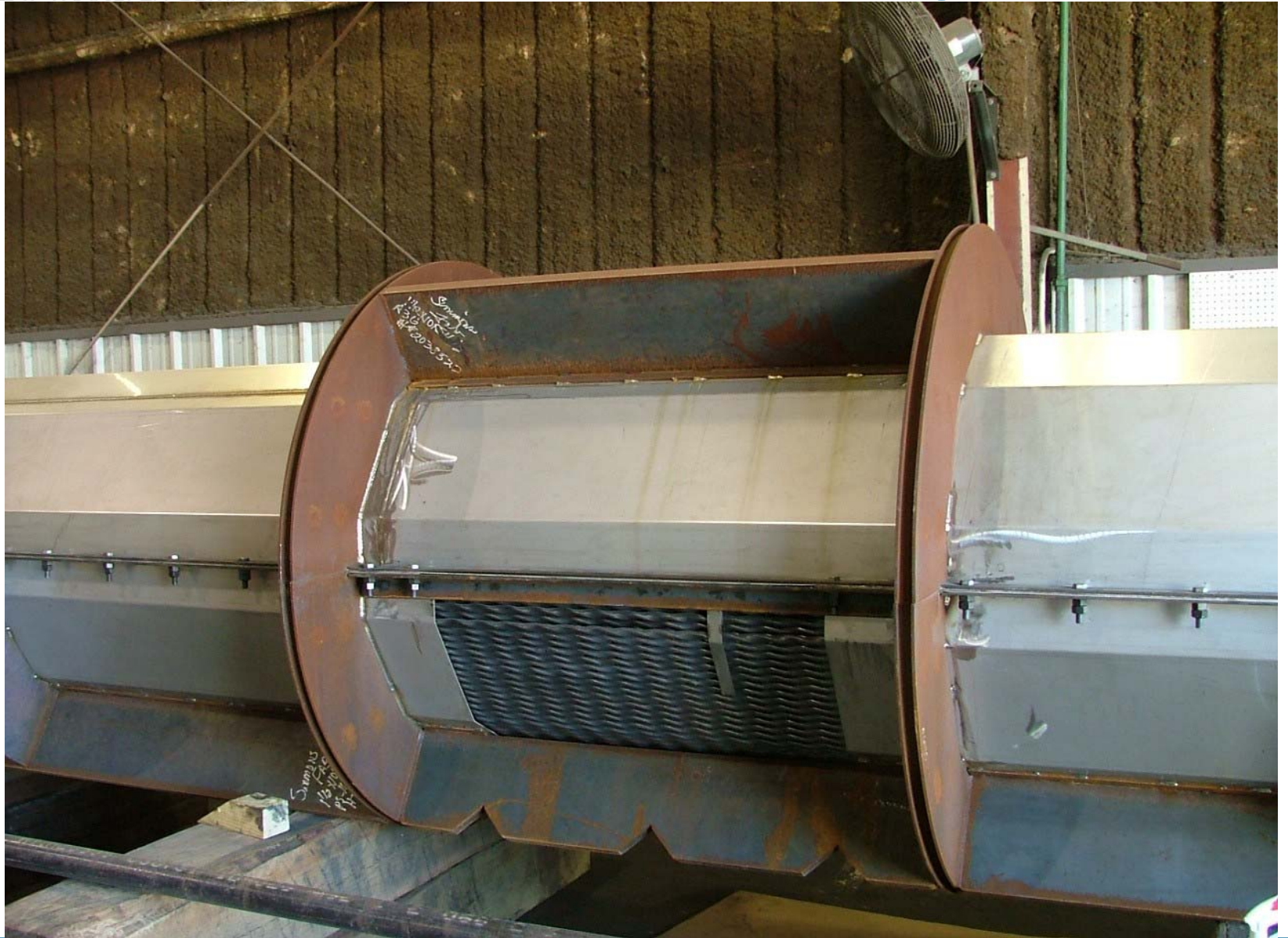

Heat Transfer Solutions Case Studies



Crude Preheat Case Study

Project Objectives:

- Increase Heat Input to Crude Pre-flash Drum
- Reduced demand on Overhead Condenser (constraint)
- Increase Crude Throughput via Reduced Pressure Drop through Exchangers
- Reduce Vacuum Tower Flash Zone Pressure

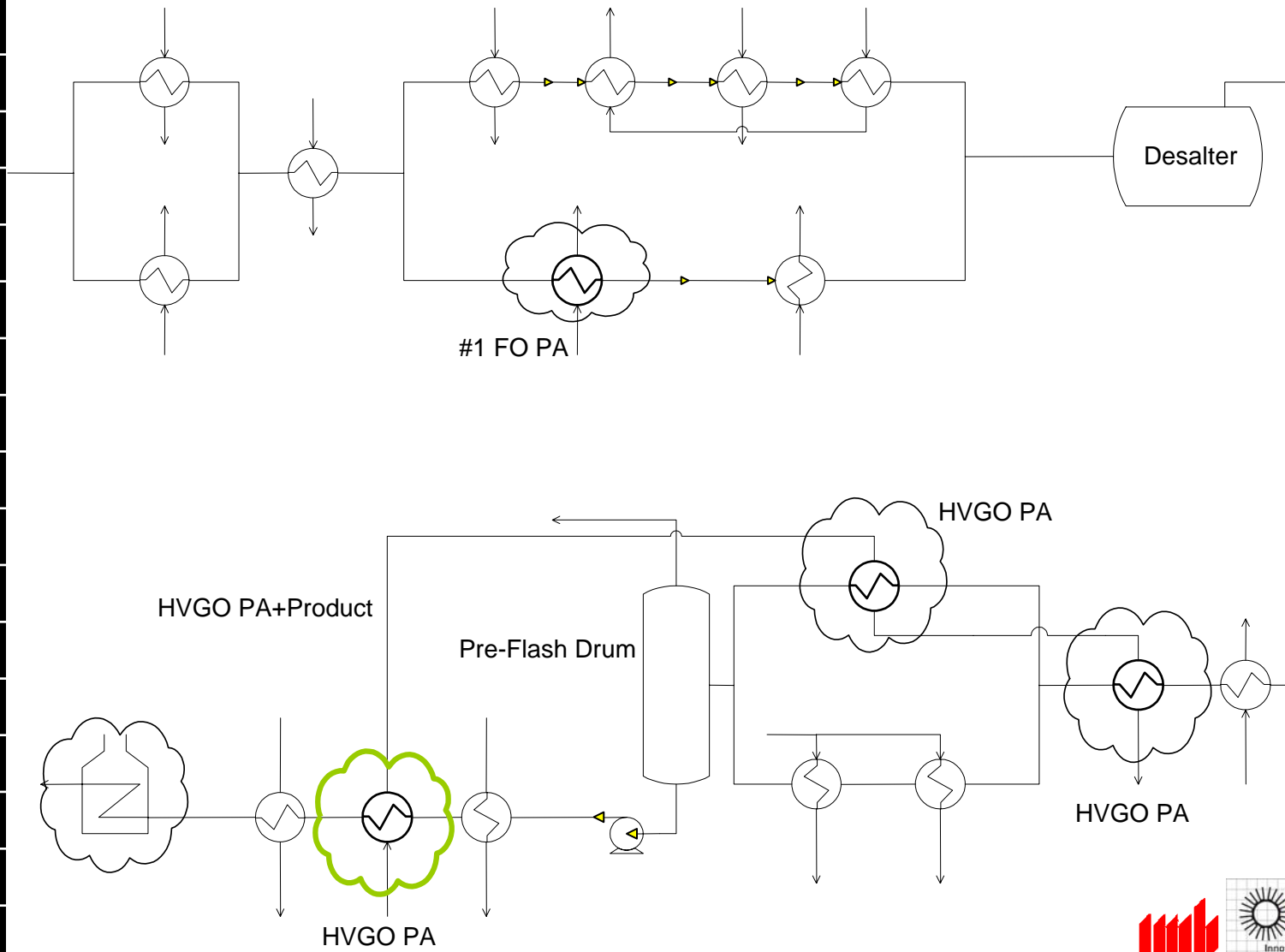

HVGO PA Exchangers After Preflash

- 1 p x 3 s Configuration
- 57-216 AET, 2844 Tubes
- Crude Velocity: 2.7 ft/sec
- HVGO Velocity: 2.0 ft/sec

Crude Rate vs. U Value

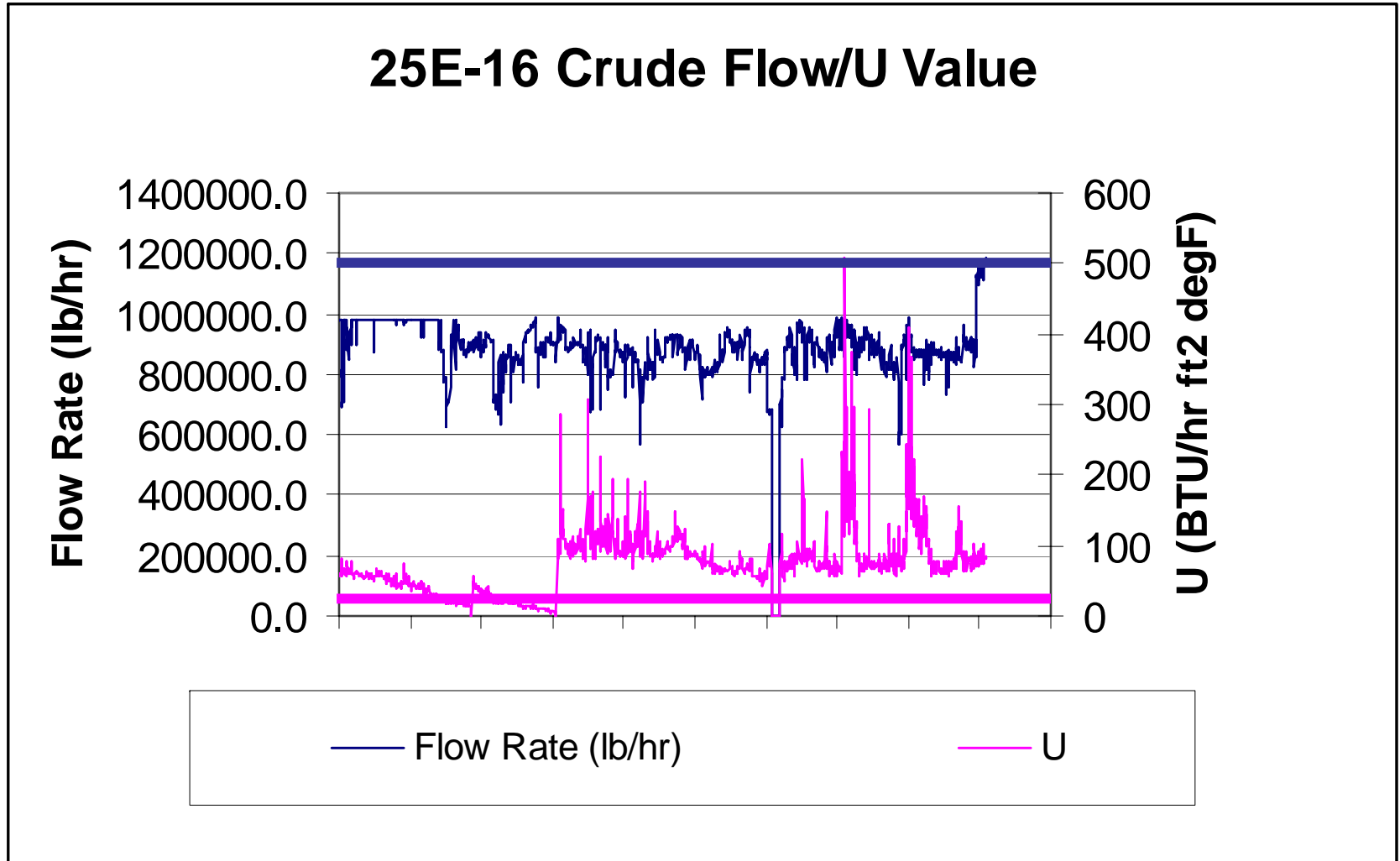

Current Process Conditions

Crude Rate 116,000 bpd

	Plain ⁽¹⁾	Twisted
Shellside DP (psi)	13.2	3.5
Tubeside Reynolds #	14,600	10,000
Tubeside h (BTU/ft ² -hr-F)	148.7	208.5
UA(BTU/hr-F)	1.6 mm	2.0 mm
% OD	-21%	15%

(1) Data simulated using HTRI software.

(2) No fouling factors used.

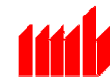

KOCH

HEAT TRANSFER COMPANY LP



Improvements

- Reduced Overall HVGO Pressure Drop by 100 PSI
- Reduced Crude Stream Pressure Drop by 10 PSI
- Gained Capacity and Improved Yield of Vacuum Gas Oil
- HVGO Pumparound Vacuum Flash Zone reduced by 4 mm Hg

Economics

- Fuel Savings - 19.5 - 25 MM Btu/Hr
- Vacuum Tower Cut Point Increase –
640 - 1540 Bbl/day
- Expected Increase in Profits:\$ 3.5 - 8.1
MM/year

Twisted Tube® - Technology

Replacement Bundle Criteria

- Removable Bundles.
- Square Pitch Tube Layout.
- Tubeside Controlled U-value.
- Lower Shellside Pressure Drop Valued.
- More Than 2 Passes Tube Side.
- Vibration Problem or Risk.
- Duty Limited.
- High Cost of Field Modifications.

Complete Exchanger Criteria

- Above Items plus:
 - High Alloy Shell Materials
 - Multiple Shells in Series (Temperature Cross)

Successful Applications

- Crude Preheat
- Hydrotreating/Reforming Feed Effluent Exchangers
- 100% Vaporization Processes
- Reboilers – Any TEMA-Type
- Condensers
- Energy Reduction Projects.
- Debottle-Necking Projects